

General Data

Cutting off the shaft & applying the handle

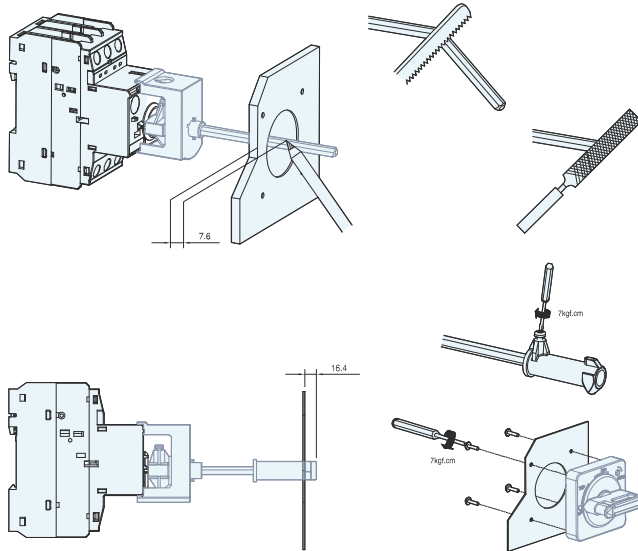

Enclosure

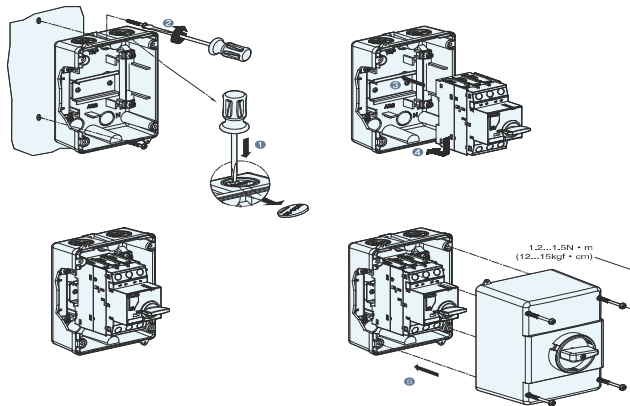

Manual Motor Controller (UL508, CSA, C22.2)

- Combination Motor Controller
- Group Installation
- Type E Starter

• TCMS 32S

Rated operational current I _e [A]		0.16	0.25	0.4	0.63	1	1.6	2.5	4	6	8	10	13	17	22	26	32
Max. short-circuit current																	
240V	[kA]	100	100	100	100	100	100	100	100	100	100	50	50	40	30	30	20
480V	[kA]	50	50	50	50	50	50	50	50	25	25	10	10	10	10	7.5	7.5
600V	[kA]	10	10	10	10	10	10	10	5	5	5	5	5	5	5	5	5
Motor load																	
1 Phase																	
115V	[HP]	-	-	-	-	-	-	-	1/8	1/4	1/3	1/2	1/2	1	1.5	2	2
230V	[HP]	-	-	-	-	-	1/10	1/6	1/3	1/2	1	1.5	2	3	3	3	5
3 Phase																	
200V	[HP]	-	-	-	-	-	-	1/2	3/4	1	2	3	3	5	7.5	7.5	7.5
230V	[HP]	-	-	-	-	-	-	1/2	3/4	1.5	2	3	3	5	7.5	7.5	10
460V	[HP]	-	-	-	-	-	3/4	1	2	3	5	5	7.5	10	15	15	20
575V	[HP]	-	-	-	-	1/2	3/4	1.5	3	5	5	7.5	10	15	20	20	30
Maximum rated current of fuse or breaker		[A]	1	1	1	1	3	6	10	15	20	30	40	50	60	80	100
Max. breaker size		[A]	15	15	15	15	15	15	15	20	30	40	50	60	80	100	125

• TCMS 32H

Rated operational current I _e [A]		0.16	0.25	0.4	0.63	1	1.6	2.5	4	6	8	10	13	17	22	26	32
Max. short-circuit current																	
240V	[kA]	100	100	100	100	100	100	100	100	100	100	100	100	100	100	100	100
480V	[kA]	50	50	50	50	50	50	50	50	50	50	50	50	50	50	50	50
600V	[kA]	10	10	10	10	10	10	10	10	10	10	10	10	10	10	10	10
Motor load																	
1 Phase																	
115V	[HP]	-	-	-	-	-	-	-	1/8	1/4	1/3	1/2	1/2	1	1.5	2	2
230V	[HP]	-	-	-	-	-	1/10	1/6	1/3	1/2	1	1.5	2	3	3	3	5
3 Phase																	
200V	[HP]	-	-	-	-	-	-	1/2	3/4	1	2	3	3	5	7.5	7.5	7.5
230V	[HP]	-	-	-	-	-	-	1/2	3/4	1.5	2	3	3	5	7.5	7.5	10
460V	[HP]	-	-	-	-	-	3/4	1	2	3	5	5	7.5	10	15	15	20
575V	[HP]	-	-	-	-	1/2	3/4	1.5	3	5	5	7.5	10	15	20	20	30
Max. fuse size		[A]	1	1	1	1	3	6	10	15	20	30	40	50	60	80	100
Max. breaker size		[A]	15	15	15	15	15	15	15	20	30	40	50	60	80	100	125

• TCMS 63H

Rated operational current I _e [le]		10	13	17	22	26	32	40	50	63
Max. short-circuit current										
240V	[kA]	100	100	100	100	100	100	100	100	100
480V	[kA]	50	50	50	50	50	50	50	50	50
600V	[kA]	10	10	10	10	10	10	10	10	10
Motor load										
1 Phase										
115V	[HP]	1/2	1/2	1	1.5	2	2	3	3	5
230V	[HP]	1.5	2	3	3	3	5	7.5	10	10
3 Phase										
200V	[HP]	2	3	3	5	7.5	7.5	10	15	20
230V	[HP]	3	3	5	7.5	7.5	10	10	15	20
460V	[HP]	5	7.5	10	15	15	20	30	30	40
575V	[HP]	7.5	10	15	20	20	30	30	40	60
Max. fuse size		[A]	40	50	60	80	100	125	150	200
Max. breaker size		[A]	40	50	60	80	100	125	150	200



• TCMS 100H

Rated operational current I _e [le]		17	22	26	32	40	50	63	75	90	100
Max. short-circuit current											
240V	[kA]	100	100	100	100	100	100	100	100	100	100
480V	[kA]	50	50	50	50	50	50	50	50	50	50
600V	[kA]	10	10	10	10	10	10	10	10	10	10
Motor load											
1 Phase											
115V	[HP]	1	1.5	2	2	3	3	5	5	7.5	10
230V	[HP]	3	3	3	5	7.5	10	10	15	20	20
3 Phase											
200V	[HP]	3	5	7.5	7.5	10	15	20	20	25	30
230V	[HP]	5	7.5	7.5	10	10	15	20	25	30	30
460V	[HP]	10	15	15	20	30	30	40	50	60	75
575V	[HP]	15	20	20	30	30	40	60	60	75	100
Max. fuse size		[A]	60	80	100	125	150	200	250	300	350
Max. breaker size		[A]	60	80	100	125	150	200	250	300	350

Quick selection table... IEC rating



TCMS-32S



TCMS-32HI



TCMS-63H



TCMS-100H

Frame		32AF											
Type	Current adjustable type	TCMS-32S						TCMS-32H					
	Instantaneous type	-						TCMS-32HI					
Breaking capacity		Standard						High breaking					
Handle Type		Toggle						Rotary					
Number of poles		3						3					
Rated operational voltage (Ue)		Up to 690V						Up to 690V					
Rated frequency		50/60 Hz						50/60 Hz					
Rated insulation voltage (Ui)		690V						690V					
Rated impulse voltage (Uimp)		6kV						6kV					
Utilization category	IEC 60 947-2 (Breaker)	Cat. A						Cat. A					
	IEC 60 947-4 (Motor starter)	AC 3						AC 3					
Mechanical endurance (Operating)		100,000						100,000					
Electrical endurance (Cycles)		100,000						100,000					
Max operating frequency per hour (Opm/h)		25						25					
Temperature compensation (Operation)		-20 ~ +60 ?						-20 ~ +60 ?					
Instantaneous short circuit release		13 x Ie max.						13 x Ie max.					
Overload protection		O						O					
Phase failure function		O						O					
Trip indicating function		O						O					
Test function		O						O					
Weight (g)		320						360					

Rated breaking capacity (kA)	Rated operational current (Ie)	Thermal release Adjustment range (A)	240V* 230V#		415V* 400V#		460V* 440V#		525V* 500V#		690V* 600V#		230V* 240V#		415V* 400V#		460V* 440V#		525V* 500V#		690V* 600V#			
			Icu	Ics	Icu	Ics	Icu	Ics	Icu	Ics	Icu	Ics	Icu	Ics	Icu	Ics	Icu	Ics	Icu	Ics	Icu	Ics	Icu	Ics
			0.16	0.1-0.16	100	100	100	100	100	100	100	100	100	100	100	100	100	100	100	100	100	100	100	100
0.25	0.16-0.25	100	100	100	100	100	100	100	100	100	100	100	100	100	100	100	100	100	100	100	100	100	100	100
0.4	0.25-0.4	100	100	100	100	100	100	100	100	100	100	100	100	100	100	100	100	100	100	100	100	100	100	100
0.63	0.4-0.63	100	100	100	100	100	100	100	100	100	100	100	100	100	100	100	100	100	100	100	100	100	100	100
1	0.63-1	100	100	100	100	100	100	100	100	100	100	100	100	100	100	100	100	100	100	100	100	100	100	100
1.6	1-1.6	100	100	100	100	100	100	100	100	100	100	100	100	100	100	100	100	100	100	100	100	100	100	100
2.5	1.6-2.5	100	100	100	100	100	100	100	100	3	3	100	100	100	100	100	100	100	100	100	100	100	100	100
4	2.5-4	100	100	100	100	100	100	50	38	3	3	100	100	100	100	100	100	100	100	100	100	8	8	8
6	4-6	100	100	100	100	50	38	15	11	3	3	100	100	100	100	100	100	100	100	100	100	8	8	8
8	5-8	100	100	100	100	15	11	10	8	3	3	100	100	100	100	100	100	100	100	100	100	6	6	6
10	6-10	100	100	100	100	15	11	10	8	3	3	100	100	100	100	50	38	50	38	6	6	6	6	6
13	9-13	100	100	50	38	15	11	6	5	3	3	100	100	100	100	50	38	50	38	6	6	6	6	6
17	11-17	100	100	50	38	10	8	6	5	3	3	100	100	100	100	50	38	42	32	6	6	6	6	6
22	14-22	50	38	20	15	10	8	6	5	3	3	100	100	50	38	20	15	10	8	4	4	4	4	4
26	18-26	40	30	15	11	8	6	6	5	3	3	100	100	50	38	20	15	10	8	4	4	4	4	4
32	22-32	40	30	15	11	8	6	6	5	3	3	100	100	50	38	20	15	10	8	4	4	4	4	4
40	28-40	30	22	15	11	6	4	5	4	3	3	100	100	50	38	20	15	10	8	4	4	4	4	4
50	34-50	-	-	-	-	-	-	-	-	-	-	-	-	-	-	-	-	-	-	-	-	-	-	-
63	45-63	-	-	-	-	-	-	-	-	-	-	-	-	-	-	-	-	-	-	-	-	-	-	-
75	55-75	-	-	-	-	-	-	-	-	-	-	-	-	-	-	-	-	-	-	-	-	-	-	-
90	70-90	-	-	-	-	-	-	-	-	-	-	-	-	-	-	-	-	-	-	-	-	-	-	-
100	80-100	-	-	-	-	-	-	-	-	-	-	-	-	-	-	-	-	-	-	-	-	-	-	-

* Permissible up to 5% over Voltage
Permissible up to 5% over Voltage

63AF												100AF											
TCMS-63H												TCMS-100H											
TCMS-32HI												TCMS-100HI											
High break												High breaking											
Rotary												Rotary											
3												3											
Up to 690V												Up to 690V											
50 / 60 Hz												50 / 60 Hz											
1000V												1000V											
8kA												8kA											
Cat. A												Cat. A											
AC 3												AC 3											
50,000												50,000											
25,000												25,000											
25												25											
-20 ~ +60 °C												-20 ~ +60 °C											
13 x Ie max.O												13 x Ie max.O											
O												O											
O												O											
O												O											
O												O											
1,000												2,200											

240V 230V		415V 400V		460V 440V		525V 500V		690V 600V		240V 230V		415V 400V		460V 440V		525V 500V		690V 600V	
Icu	Ics	Icu	Ics	Icu	Ics	Icu	Ics	Icu	Ics	Icu	Ics	Icu	Ics	Icu	Ics	Icu	Ics	Icu	Ics
-	-	-	-	-	-	-	-	-	-	-	-	-	-	-	-	-	-	-	-
-	-	-	-	-	-	-	-	-	-	-	-	-	-	-	-	-	-	-	-
-	-	-	-	-	-	-	-	-	-	-	-	-	-	-	-	-	-	-	-
-	-	-	-	-	-	-	-	-	-	-	-	-	-	-	-	-	-	-	-
100	100	100	100	50	38	50	38	6	5	-	-	-	-	-	-	-	-	-	-
100	100	100	100	50	38	42	32	6	5	-	-	-	-	-	-	-	-	-	-
100	100	50	50	50	38	12	9	5	5	100	100	100	50	50	38	35	27	12	9
100	100	50	50	50	38	12	9	5	5	100	100	100	50	50	38	35	27	12	9
100	100	50	50	35	27	12	9	5	5	100	100	100	50	50	38	35	27	12	9
100	100	50	50	35	27	10	8	5	5	100	100	100	50	50	38	25	19	12	9
100	100	50	50	35	27	10	8	5	5	100	100	100	50	50	38	25	15	12	9
100	100	50	50	35	27	10	8	5	5	100	100	100	50	50	38	15	11	10	8
100	100	50	50	35	27	10	8	5	5	100	100	100	50	50	38	15	11	8	6
-	-	-	-	-	-	-	-	-	-	100	100	100	50	50	38	12	9	6	6

Time/Current characteristic

**TCMS-32AF
Tripping Curve**

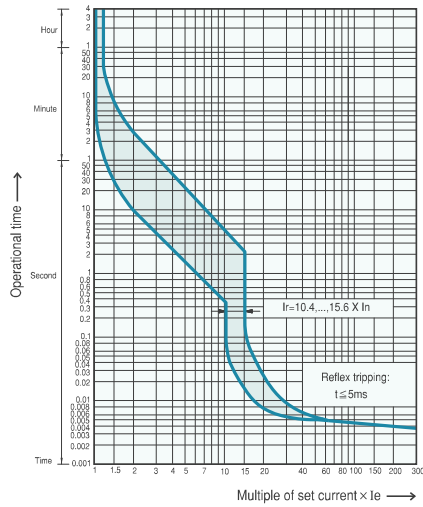

**TCMS-63, 100AF
Tripping Curve**

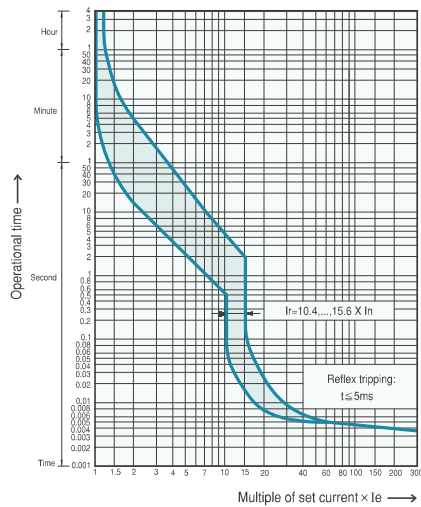

1. Thermal release trip current:

The adjustable inverse bimetal trip reliability protects motors against overloads. The curve shows the mean operating current at an ambient temperature of 20°C starting from cold. Careful testing and setting ensures effective motor protection even in the case of single-phasing.

2. Magnetic release trip current:

The instantaneous magnetic trip has a fixed operating current setting. This corresponds to 13 times the maximum value of setting range, at a lower setting it is correspondingly higher.

3. Current setting I_e :

The overload trip corresponds to a thermal overload relay in a motor starter conforming to IEC 947-4-1. If a different value is prescribed (e.g. reduced I_e for cooling medium having a temperature higher than 40°C or a place of installation higher than 2000m above sea level) the setting current is equal to the reduced rated current I_e of the motor.

• TCMS 32H, 32HI

[mm]

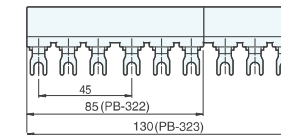
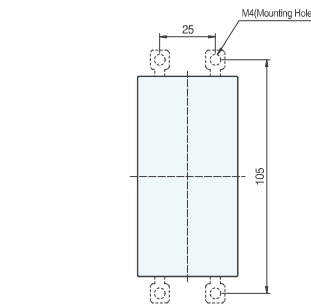
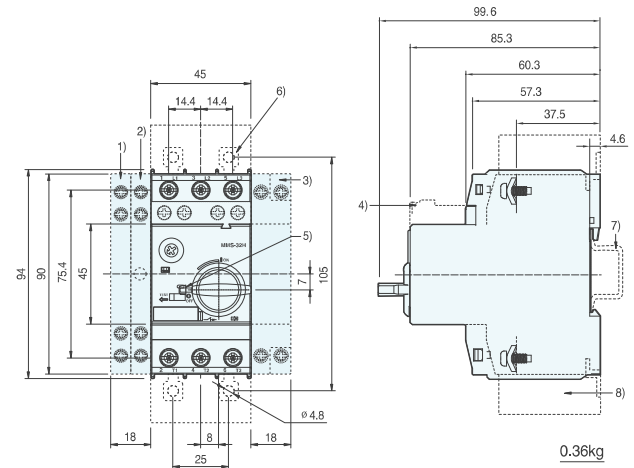

TCMS-32H/Hi+PB-32(2,3 Terminal)
PB-322(2 Terminal), PB-323(3 Terminal)

Height of arcing spaces
(Clearance from earthed parts)

Ue[V]	240	415	460	525	690
[mm]	30	30	30	30	50

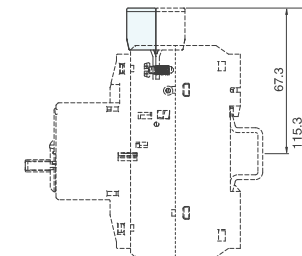

Dimensions

● TCMS 100S, 100H, 100HI

[mm]

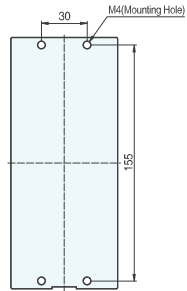
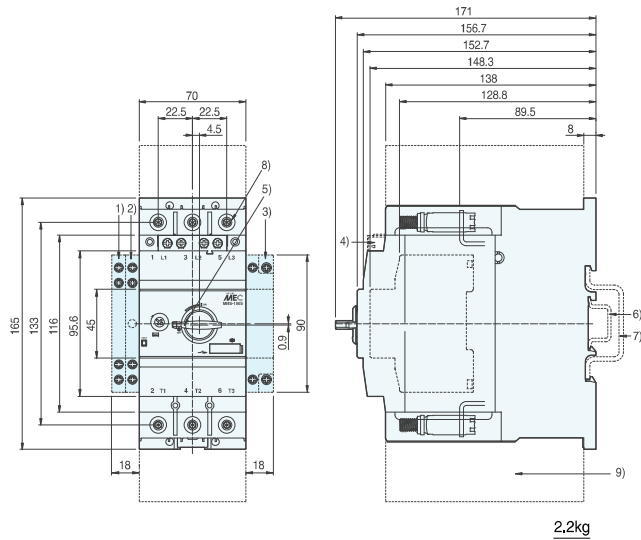

Height of arcing spaces
(Clearance from earthed parts)

U _e [V]	240	415	460	525	690
[mm]	50	70	70	110	150

Dimensions

● E-Handle

[mm]

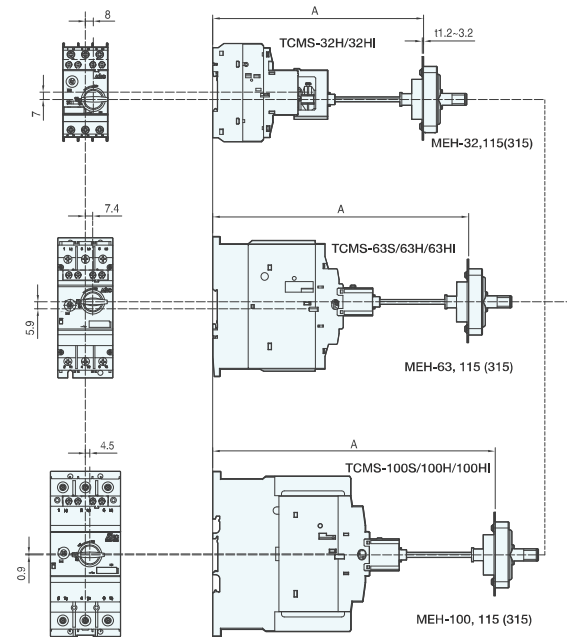

E-Handle Type	A(mm)	TCMS Type
MEH-32, 115	min : 148,6	TCMS-32H/32HI
	max:210,6(Shaft 115mm)	
MEH-32, 315	min : 148,6	TCMS-63S/63H/63HI
	max:410,6(Shaft 315mm)	
MEH-63, 115	min : 193,6	TCMS-63S/63H/63HI
	max:255,6(Shaft 115mm)	
MEH-63, 315	min : 193,6	TCMS-63S/63H/63HI
	max:455,6(Shaft 315mm)	
MEH-100, 115	min : 220	TCMS-100S/100H/100HI
	max:282(Shaft 115mm)	
MEH-100, 315	min : 220	TCMS-100S/100H/100HI
	max:482(Shaft 315mm)	

